

PRODUCT SHEET

Description:

Invis. Full Ext. Slide, Self Closing, Pre-Zinc, 600mm, W/Quick Release & Inner Dampers

Item number:

16.13.477-9

Units	Box	Carton	HS Code	Barcode
Pair	1	10	8302420090	 5704866000932

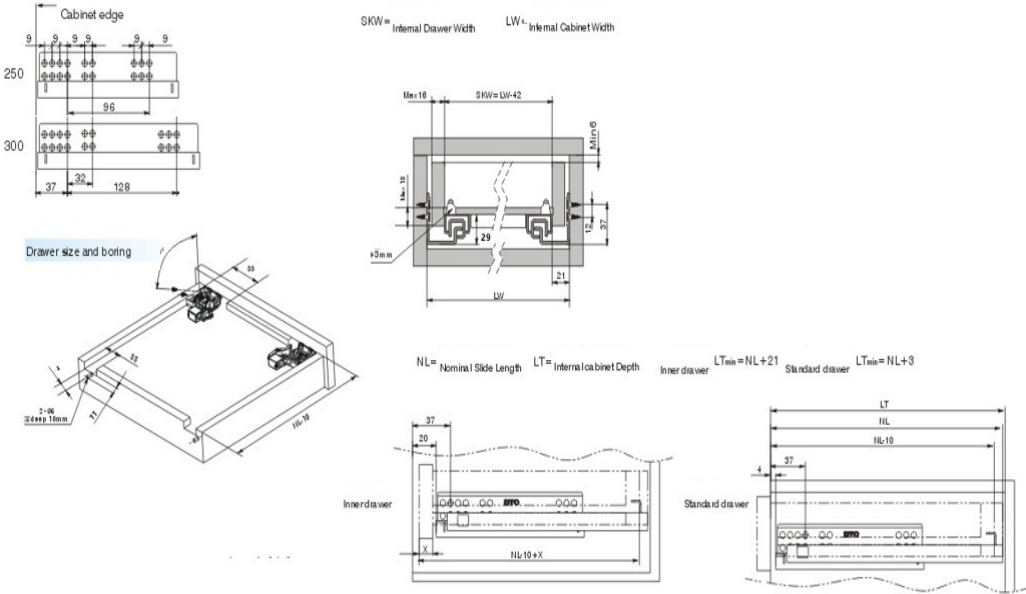

SISO A/S
Mileparken 11
DK-2740 Skovlunde
Denmark
VAT: DK 24786013

Phone +45 45 830 900
www.siso.dk
siso@siso.dk

Danske Bank
Nytov Branch
Copenhagen
SWIFT: DABADKKK

Account no.
4180 3112 112936
IBAN Account
DK7230003112112936